

# RLR

## LIQUID RECEIVERS

### INTRODUCTION

Liquid receiver is a vessel used to temporarily store the refrigerant condensed by the condenser before it is sent to the expansion valve. When the refrigeration system is shut down for a long period or undergoing maintenance, the receiver can also be used to recover and store all the refrigerant in the system (when used together with the condenser).

The liquid level inside the receiver changes according to the operating conditions of the refrigeration system. Under stable operating conditions, no matter how the refrigerant changes inside the evaporator, the liquid level in the receiver remains constant. If the liquid level in the receiver is found to be low, an appropriate amount of refrigerant should be added. Only then can a stable and sufficient liquid supply be ensured during operation.



### S-TYPE LIQUID RECEIVERS

The liquid receiver uses advanced automatic welding technology, providing high strength and excellent air-tightness. It is an ideal supporting component for refrigeration systems.

TYPE	A	B	C	WELDING	BOLT	VOLUME
RLR-SCYQ3. 1L	38	300	125	9.52	F-2	3. 1L
RLR-SCYQ6L	50	330	165	12.7	A-4	6.5L
RLR-SCYQ10L	50	310	219	16	A-6	10L
RLR-SCYQ12L	50	370	219	22	A-6	12L

The technical parameters are subject to adjustment without prior notice.

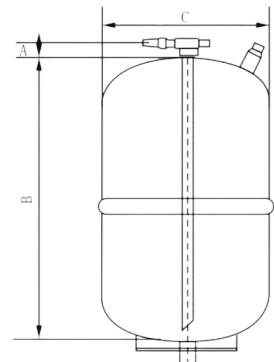

### BALANCE TANK

With only one port, it can quickly raise the system's low pressure during defrosting, increase the flow rate, and achieve efficient defrosting.

Model	A	B	C	WELDING	VOLUME	INSTALL
RLR-PHG2.8	125	250	100	9.52	2.8	E
RLR-PHG4.5	165	250	150	12.7	4.5	E

The technical parameters are subject to adjustment without prior notice.

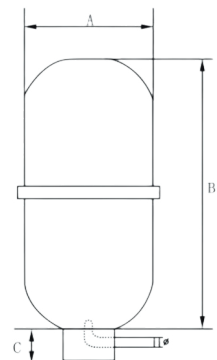

## FEATURES

The liquid receiver uses advanced automatic welding technology, ensuring high strength and excellent airtightness, making it an ideal component for refrigeration systems.

Installation options include fixed plate, bolt-mounted, and hanger-mounted types.

Refrigerant: R22/R134a/R404A/R407C/R502/R507/R410A

Max Working Pressure: 4.3MPa

Medium temperature: -40 to +120C

Destructive test is reached to four times the design pressure.

The thickness of paint film: 50-120um.

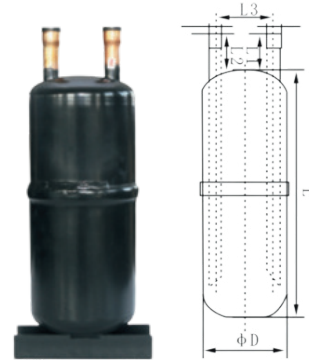

Model	d1	d2	L1	L2	L3	ΦD*1	Installation Type	Volume (L)
RLR-CYQ1.2-B-01	12.9	12.9	40	40	40	88x210	M8X20	1.2
RLR-CYQ1.6-B-01	12.9	12.9	40	40	50	100x230	M8X20	1.6
RLR-CYQ2.0-B-01	12.9	12.9	40	40	65	115x200	M8X20	2
RLR-CYQ2.0-A-01	12.9	12.9	40	40	65	115x200	F-2	2
RLR-CYQ3.0-B-01	12.9	12.9	40	40	70	125x300	M8x20	3
RLR-CYQ3.0-B-02	16.2	16.2	40	40	70	125x300	M8x20	3
RLR-CYQ3.0-A-01	12.9	12.9	40	40	70	125x300	F-2	3
RLR-CYQ3.0-A-02	16.2	16.2	40	40	70	125x300	A-1	3
RLR-CYQ4.5-B-01	16.2	16.2	40	40	70	152x300	M10x20	4.5
RLR-CYQ4.5-A-01	16.2	16.2	40	40	70	152x300	A-3	4.5
RLR-CYQ6.3-B-01	16.2	16.2	40	40	80	165x313	M10x25	6.3
RLR-CYQ8.0-A-01	16.2	16.2	40	40	80	165x407	A-3	8
RLR-CYQ8.0-B-01	16.2	16.2	40	40	80	165x407	M10x20	8
RLR-CYQ12-A-01	22.2	22.2	40	40	100	219x362	A-6	12

## D LIQUID RECEIVERS

The inlet and outlet are ODS (brazed) carbon-steel connections.

The outlet is equipped with a safety-valve port (1/2" NPT).

Installation methods: vertical installation / horizontal installation

Maximum allowable operating pressure: 4.3 MPa

Maximum allowable operating temperature: 100°C

Refrigerants: R134a, R404A, R407A, R407C, R507, R22, R410A.

Model	Inside				
	D (mm)	H (mm)	Thread (NPT)	In-let OD (Inch)	Out-let OD (Inch)
RLR-CYQ30L	325	600	1/2	1-3/8	1-3/8
RLR-CYQ40L	325	800	1/2	1-3/8	1-3/8
RLR-CYQ60L	426	600	1/2	1-5/8	1-5/8
RLR-CYQ80L	426	800	1/2	1-5/8	1-5/8
RLR-WCYQ30L	325	600	1/2	1-3/8	1-3/8
RLR-WCYQ40L	325	800	1/2	1-3/8	1-3/8
RLR-WCYQ60L	426	600	1/2	1-5/8	1-5/8
RLR-WCYQ80L	426	800	1/2	1-5/8	1-5/8

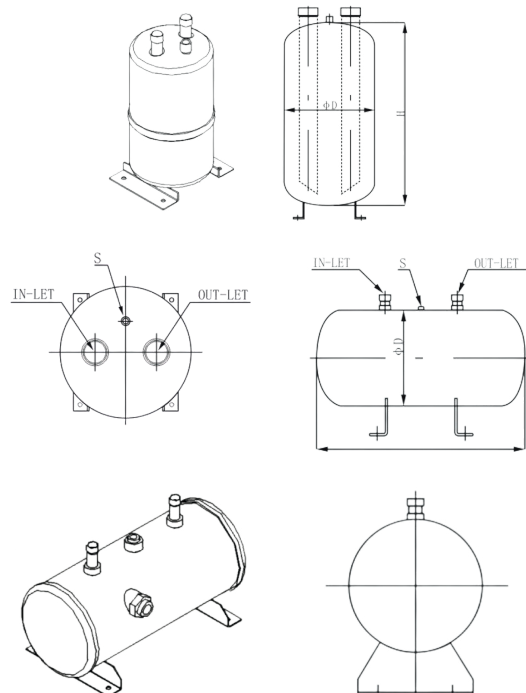

The technical parameters are subject to adjustment without prior notice.

## GAS-LIQUID SEPERATOR

The gas-liquid separator uses an internal bent-tube design to prevent internal splashing, helping oil to accumulate at the bottom of the separator, and it should be installed as close to the compressor as possible.

Installation options include fixed plate, bolt-mounted, and hanger-mounted types.

Suitable for CFC, HCFC, and HFC refrigerants

Corrosion-resistant powder coating

Maximum working pressure: 4.3 MPa

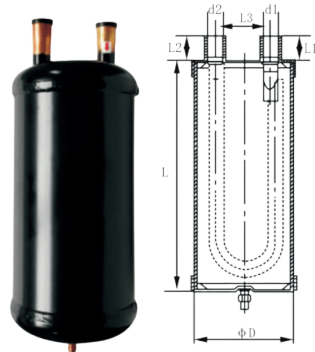
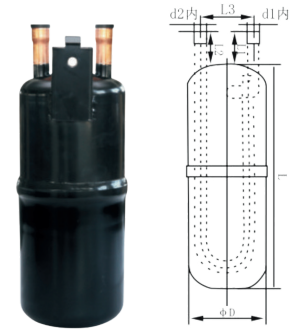

Model	d1	d2	L1	L2	L3	ΦD*L	Bolt	Volume (L)
RLR-QFQ2.0-A-01	16.2	16	40	40	65	115x200	F-2	2.0
RLR-QFQ2.0-B-01	16.2	16	40	40	65	115x200	M8X20	2.0
RLR-QFQ2.0-A-02	19.2	19	40	40	65	115x200	F-2	2.0
RLR-QFQ2.0-B-02	19.2	19	40	40	65	115x200	M8X20	2.0
RLR-QFQ3.0-A-01	19.2	19	50	50	70	125x300	F-2	3.0
RLR-QFQ3.0-B-01	19.2	19	40	40	70	125x300	M8X20	3.0
RLR-QFQ3.0-A-02	22.2	22	40	40	70	125x300	F2	3.0
RLR-QFQ3.0-B-02	22.2	22	40	40	70	125x300	M8X20	3.0
RLR-QFQ3.2-B-01	19.2	19	40	40	70	127x280	M10X20	3.2
RLR-QFQ3.5-A-01	19.2	19	40	40	70	127x300	A-2	3.5
RLR-QFQ3.5-B-01	19.2	19	40	40	70	127x300	M8X20	3.5
RLR-QFQ3.5-A-02	22.2	22	40	40	70	127x300	A-2	3.5
RLR-QFQ3.5-B-02	22.2	22	40	40	70	127x300	M10X20	3.5
RLR-QFQ4.2-B-01	19.2	19	50	50	70	127x360	M8X20	4.2
RLR-QFQ4.6-A-01	22.2	22	40	40	70	152x280	A-3	4.6
RLR-QFQ4.6-B-01	22.2	22	40	40	70	152x280	M10X20	4.6
RLR-QFQ5.2-B-01	28.6	29	55	65	75	152x320	M10X20	5.2
RLR-QFQ6.3-A-01	19.2	19	30	30	80	165x313	A-3	6.3
RLR-QFQ6.3-B-01	19.2	19	30	30	80	165x313	M10X20	6.3
RLR-QFQ6.3-A-02	22.2	22	40	40	80	165x313	A-3	6.3
RLR-QFQ6.3-B-02	22.2	22	40	40	80	165x313	M10X25	6.3
RLR-QFQ6.5-B-01	28.6	29	45	45	75	165x330	M10X20	6.5
RLR-QFQ8.0-A-01	28.6	29	45	45	75	165x407	A-3	8.0
RLR-QFQ10-B-02	35	35	50	50	115	219x300	M10X20	10
RLR-QFQ12-B-01	28.6	29	57	57	80	219x362	M10X20	12
RLR-QFQ23-A-01	42	42	55	55	115	219x650	A-6	23

## D ACCUMULATOR

Model	D (mm)	H (mm)	S Inside Thread (NPT)	In-Let OD(inch)	Out-Let OD(inch)
RLR-QFQ30L	273	650	1/2	1-5/8	1-5/8
RLR-QFQ40L	325	650	1/2	1-5/8	1-5/8
RLR-QFQ60L	426	600	1/2	2-1/8	2-1/8
RLR-QFQ80L	426	800	1/2	2-1/8	2-1/8
RLR-QFQ100L	426	1000	1/2	2-5/8	2-5/8
RLR-QFQ120L	426	1200	1/2	3-1/8	3-1/8

The technical parameters are subject to adjustment without prior notice.

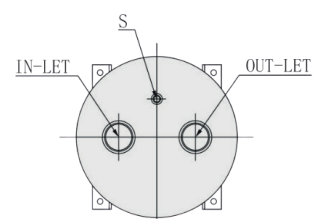
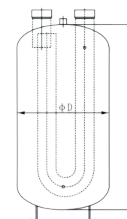
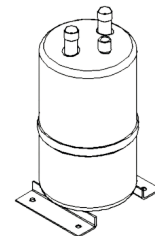
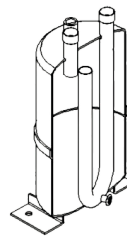

## OIL SEPERATOR

Installed between the compressor and the condenser, it separates and filters out the oil droplets contained in the discharge gas by changing the airflow speed and direction, and returns the oil to the compressor through the oil return mechanism.

Suitable for CFC, HCFC, and HFC refrigerants

Corrosion-resistant powder coating

Maximum working pressure: 4.3 MPa.

Model	Φ	D	L1	L2	L3	H	Match Model	Corresponding Model
RLR-W01-D02001	12.8	88.5	185.5	332	239	117.5	10HP	RLR-YFQ1.4-C-01
RLR-W07R-D01003	19.2	125	185.5	332	239	155	20HP	RLR-YFQ2.8-C-01

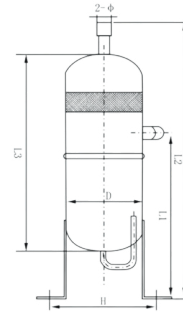

## YFQ OIL SEPERATOR

The oil separator has the ability to separate oil from the refrigerant gas mixture, ensuring the safe and efficient operation of the air-conditioning system. The mixture of refrigerant and oil discharged from the compressor enters the inlet of the oil separator, passes through the separator's filter and baffle mechanism, causing fine oil particles to gather and fall to the bottom. The refrigerant gas exits through the outlet after the filter removes any remaining oil particles, allowing oil-free refrigerant to enter the condenser.

The separated oil accumulates at the bottom of the oil separator, and the float valve automatically opens to return the oil to the compressor. Because the pressure inside the oil separator is higher than the crankcase pressure, the oil quickly returns to the compressor. When the oil level inside the separator drops, the float valve automatically closes to prevent refrigerant gas from flowing back into the compressor.

Closed structure with a steel oil-return system

Corrosion-resistant powder coating

Reliable float shut-off system

Suitable for CFC, HCF, and HFC refrigerants

Maximum working pressure: 4.3 MPa

Model	Connection		Oil Return Port		Φ (mm)	L (mm)
	Inch	mm	Welding port	Flare Port		
RLR-YFQ-408	1/2	12.9	9.7	5/8	102	255
RLR-YFQ-4115	5/8	16.2	9.7	5/8	102	305
RLR-YFQ-4147	7/8	22.4	9.7	5/8	102	345
RLR-YFQ-4149	1-1/8	28.8	9.7	5/8	102	365
RLR-YFQ-41611	1-3/8	35	9.7	5/8	102	450
RLR-YFQ-61611	1-3/8	35	9.7	5/8	159	430
RLR-YFQ-61913	1-5/8	42	9.7	5/8	159	430

